

Installation instructions



Example of an asymmetrical cover construction



Example of a symmetrical cover construction

Scope of use

The installation of the heavy duty expansion joint solutions covers is, in principle, the same and can be shown using cover FS 75 as an example. It also applies accordingly to the following covers:

- FS 40
- FS 46
- FS 50
- FS 75
- FSL 77
- SFS 90
- FS 99
- FS 100
- FSL 104
- FS 105
- FS 110
- FS 110 ES
- FSL 113
- SFS 115
- FS 130
- SFS 135
- FS 155
- FS 160
- FS 185
- FSV 235
- FSV 280
- FSV 285
- FSV 335
- FSV 500

Technical data regarding the covers can be found on the Internet at www.migua.com

MIGUTRANS

1. General Information

Please check prior to starting with the installation to make sure that the supplied material is complete and undamaged. Any damages or missing components must be reported to MIGUA without delay.

Check whether the material and the on-site characteristics correspond to the technical data detailed in the datasheet. Pay particular attention to the existing joint width. It may not be larger than the maximum joint width specified in the technical data of the cover.

Check the previous work carried out by other workers to ensure correct and fault-free execution. Check, in particular, whether the cut-out has the correct width, whether surface is capable of supporting the payload, free of cracks and the joint flanks show no signs of break-out. In doing so, the maximum permitted joint width of the cover may not be exceeded, even when taking into account the deviation of the linearity of the joint.

The cut-out should be 100mm wider than the overall cover width. This can be obtained from the technical data of the cover.

Coordinate the height of the installed cover (upper edge of cover) with the on-site construction experts.

2. Preparation

The concrete surface must be capable of carrying the payload, clean, dry and free of dust. The pressure resistance of the reinforced concrete must meet, at least, that of C20/25. Before installation, the cover is to be cleaned of dirt, oils and grease using a cleaning/solvent solution which leaves no residues. In order to ensure that the smoothing material is not able to enter the joint, the joint plate must protrude out of the joint by the thickness of the smoothing material. Place the heavy duty expansion joint solutions cover over the joint on the floor in order to familiarize yourself with the system and to check the correct dimensions. In the event of asymmetrical covers, attention is to be paid to ensure that the covers are arranged in the same way. To make this clear, arrows are attached to the protective film. For cover joints, the cover on both sides of the join must point in the same direction. Then store the covers alongside the joint.



MIGUTRANS

3. Creating the leveling layer

In order to level any unevenness in the raw concrete surface, smoothing material must be applied to both sides of the joint. The width of the material must be at least the width of the cover flank. A highly durable and loss-free PCC mortar, epoxy resin mortar or similar material must be used. The selection of the mortar is carried out in accordance with the on-site situation. Pay attention to the processing notes provided by the manufacturer.



4. Setting the covers

If shaped elements, for example, T-pieces or cross-pieces are available, laying should begin with these. Press the covers centrally over the joint, to the right height, into the fresh mortar bed. **Attention should be paid to ensure that the fixture flanks have no hollows and are lined fully. The fixture flanks may not reach into the joint.**

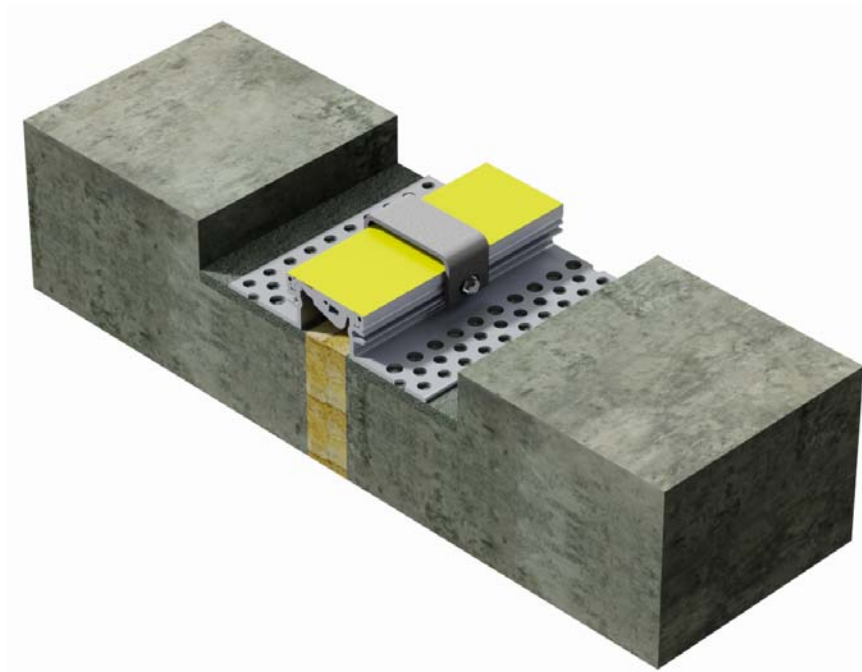

MIGUTRANS

5. Anchoring the covers

After the mortar has hardened, the fixture flanks of the cover are anchored laterally to the expansion joint into the raw concrete surface. To do this use, for example, concrete screws of type MMS 10 or similar (as of cover heights of 62mm, anchor bolts of type M8 or similar). The length of the anchor is based on the required strength (mortar layer plus cover flank strength). When using countersunk screws, the holes of the cover flank must be countersunk accordingly. The anchoring is carried out at intervals of 300mm. Pay attention to ensure vertical application of the impact screwdriver. The regulations set out by the screw manufacturer are to be observed. The clamping strengths and installation depths of the anchor manufacturer must be maintained.

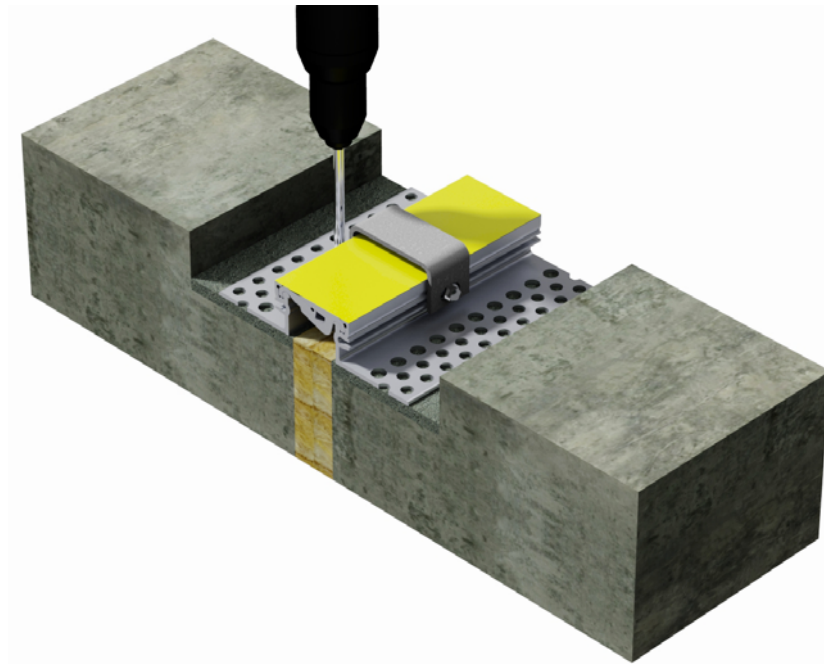

6. Removing the spacers

The factory-mounted spacers are to be removed immediately after the covers are attached. The spacers may look different according to cover. (see point 7)

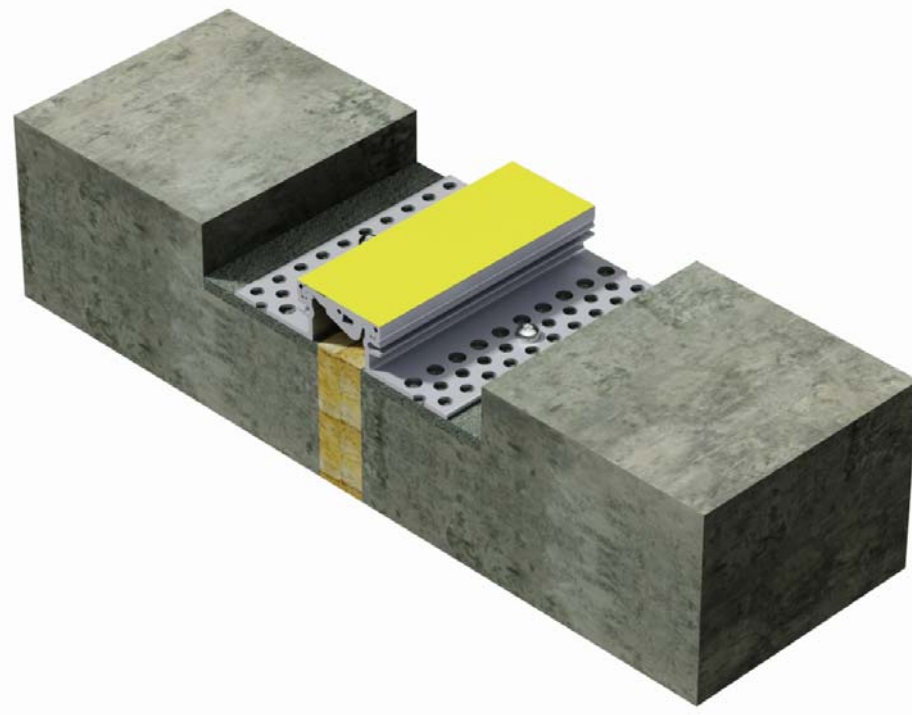

MIGUTRANS

7.1 Connecting individual lengths

In the majority of cover constructions, the correct height and flush connection of individual length is carried out using connecting pins which are fitted into the provided channels.

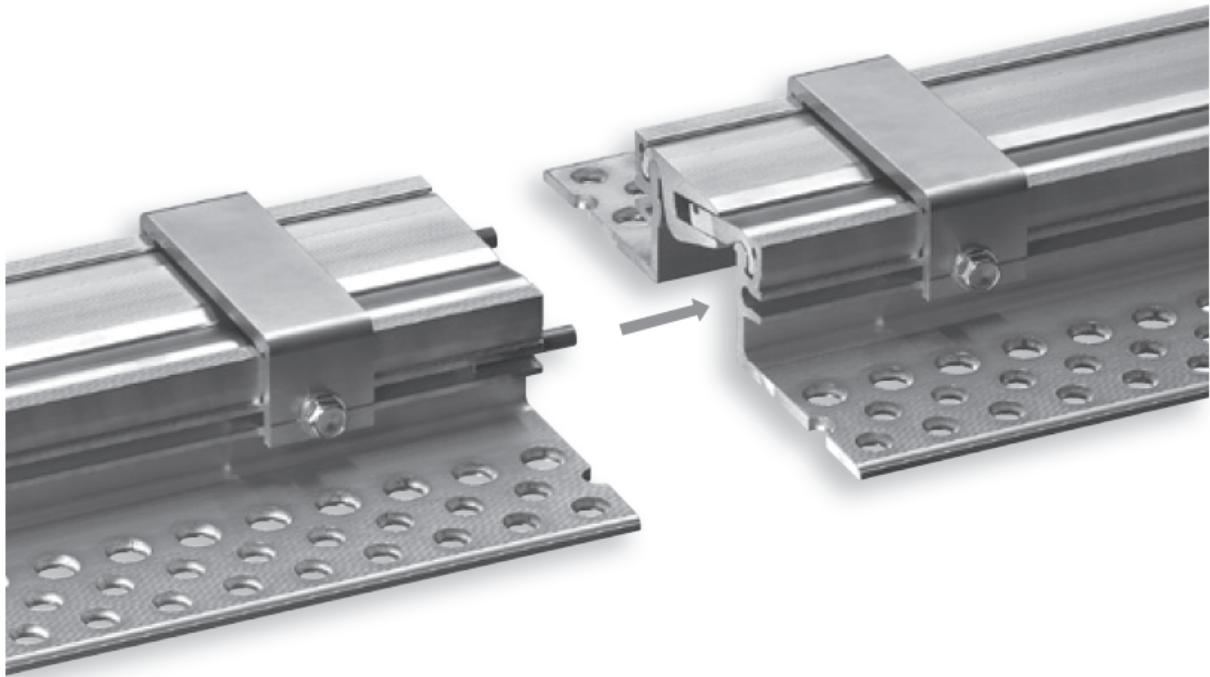

7.2 Connecting individual lengths

For some cover constructions, the connection is made by inserting the fixture flanks into one another.

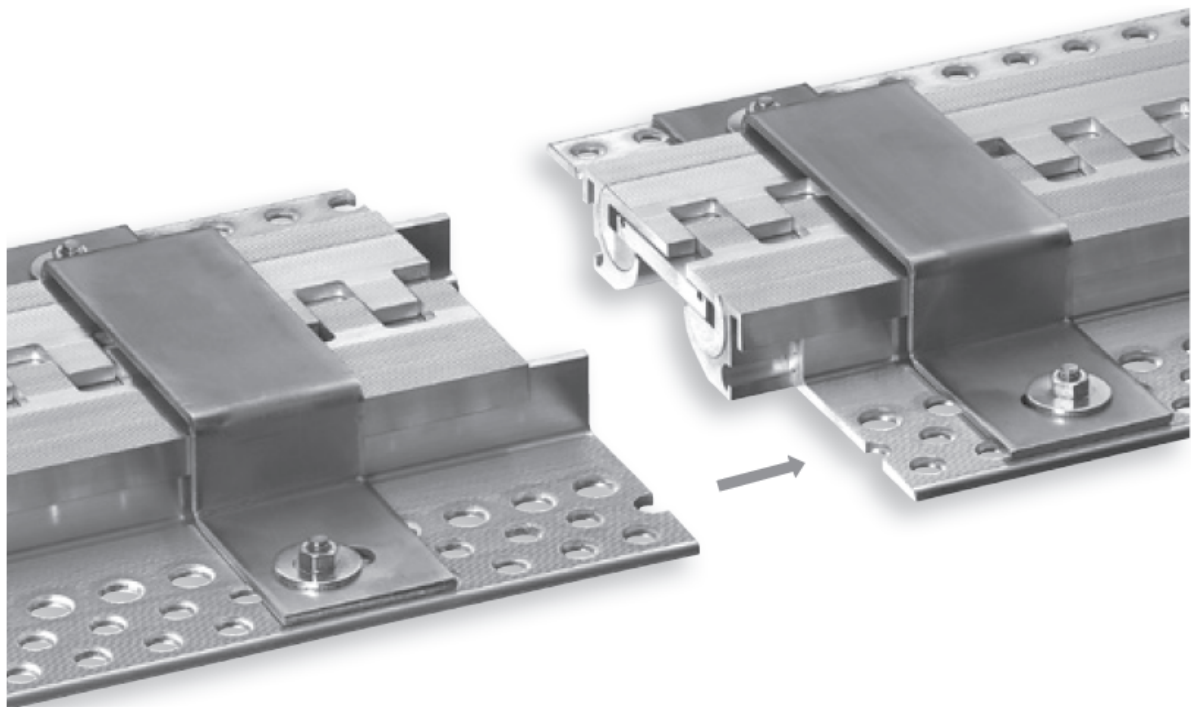

MIGUTRANS

8. Filling the cut-out/processing the covering

In the event of fixture in a cut-out:

Filling the cut-out with suitable material

Here, attention is to be paid to the subsequent usage, for example, loads caused by forklifts, abrasion, chemicals etc. The filling level is to be determined by the on-site experts whilst taking into account the subsequent flooring.

In the event of fixture without a cut-out :

Processing of flooring/floor surface

In every case, attention is to be paid to ensure that the upper edge of the neighboring surface is the same height as the cover upper edge. **The cover upper edges may not protrude.**



9. Removing the protective film

Shortly before acceptance by the client, remove the protective film and clean the cover.



More information can be found at:
www.migua.com